



中华人民共和国国家标准

GB/T 24425.3—2009

锁紧型钢丝螺套

Prevailing torque type wire thread inserts

2009-10-15 发布

2010-03-01 实施



中华人民共和国国家质量监督检验检疫总局
中国国家标准化管理委员会

发布

前 言

本部分是国家标准“钢丝螺套”系列标准之一,该系列包括:

- a) GB/T 24425.1—2009 普通型钢丝螺套;
- b) GB/T 24425.2—2009 普通型盲孔用钢丝螺套;
- c) GB/T 24425.3—2009 锁紧型钢丝螺套;
- d) GB/T 24425.4—2009 锁紧型盲孔用钢丝螺套;
- e) GB/T 24425.5—2009 钢丝螺套用内螺纹;
- f) GB/T 24425.6—2009 钢丝螺套技术条件。

本部分是 GB/T 24425 的第 3 部分。

本部分的附录 A 是资料性附录。

本部分由中国机械工业联合会提出。

本部分由全国紧固件标准化技术委员会(SAC/TC 85)归口。

本部分负责起草单位:中机生产力促进中心、沈阳市黎明机械构件制造厂。

本部分参加起草单位:上海球明标准件有限公司。

本部分由全国紧固件标准化技术委员会秘书处负责解释。

锁紧型钢丝螺套

1 范围

GB/T 24425 的本部分规定了螺纹公称直径为 3 mm~39 mm、螺距为 0.5 mm~4 mm 的对称型面锁紧型钢丝螺套。

本部分规定的钢丝螺套,旋入 GB/T 24425.5 规定的用于 5H 的内螺纹,所形成内螺纹的公差带为 5H(GB/T 197)。

本部分规定的钢丝螺套适用于提高低强度材料机体(如:铝合金、镁合金、铜合金、铸铁及非金属)螺孔的强度,提高螺钉的疲劳强度,提高锁紧性能,修复损坏的螺孔。

注:本部分使用的“螺纹公称直径”和“钢丝螺套规格”是指钢丝螺套旋入 GB/T 24425.5 规定的内螺纹后,所形成内螺纹的螺纹公称直径和螺纹规格。

2 规范性引用文件

下列文件中的条款通过 GB/T 24425 的本部分的引用而成为本部分的条款。凡是注日期的引用文件,其随后所有的修改单(不包括勘误的内容)或修订版均不适用于本部分,然而,鼓励根据本部分达成协议的各方研究是否可使用这些文件的最新版本。凡是不注日期的引用文件,其最新版本适用于本部分。

GB/T 197 普通螺纹 公差(GB/T 197—2003, ISO 965-1:1998, ISO general purpose metric screw threads—Tolerances—Part 1:Principles basic data, MOD)

GB/T 1237 紧固件标记方法(GB/T 1237—2000, eqv ISO 8991:1986)

GB/T 24425.5 钢丝螺套用内螺纹

GB/T 24425.6 钢丝螺套技术条件

3 尺寸

3.1 钢丝螺套自由状态下的型式尺寸按图 1、表 1 和表 2 的规定。



图 1 型式尺寸

表1 尺寸(粗牙螺纹)

单位为毫米

钢丝螺套规格	引导尺寸 d_y		自由状态外径 D_z		安装柄长度 T		折断槽位置 α		安装柄 转接圆弧 R_{\max}
	min.	max.	min.	max.	min.	max.	min.	max.	
M3			3.80	4.35	1.8	2.4	40°	90°	0.4
M4			5.05	5.60	2.4	3.2	40°	90°	0.5
M5			6.25	6.80	2.9	4.0	40°	90°	0.6
M6	7.28	7.58	7.58	7.95	3.5	4.8	40°	90°	0.7
M7	8.28	8.58	8.58	9.20	4.0	5.5	40°	80°	0.8
M8	9.55	9.85	9.85	10.35	4.7	6.3	40°	80°	1.0
M10	11.82	12.10	12.80	12.50	5.8	7.9	40°	80°	1.2
M12	14.20	14.50	14.50	15.00	6.9	9.5	30°	70°	1.6
M14	16.47	16.87	16.87	17.87	8.1	11.0	30°	70°	2.0
M16	18.47	18.87	18.87	19.90	9.1	12.5	30°	70°	2.0
M18	21.00	21.40	21.40	22.00	10.4	14.2	30°	70°	3.0
M20	23.01	23.46	23.46	24.40	11.4	15.7	30°	60°	3.0
M22	25.01	25.61	25.61	26.90	12.4	17.2	30°	60°	3.0
M24	27.55	28.15	28.15	29.10	13.6	18.8	30°	60°	3.0
M27	30.55	31.15	31.15	32.40	15.1	21.1	30°	60°	3.0
M30	34.10	34.70	34.70	35.81	16.9	23.4	30°	60°	3.0
M33	37.09	37.70	37.70	39.01	18.4	25.7	30°	60°	3.0
M36	40.63	41.33	41.33	42.67	20.2	28.1	30°	60°	3.0
M39	43.63	44.33	44.33	45.75	21.7	30.3	30°	60°	3.0

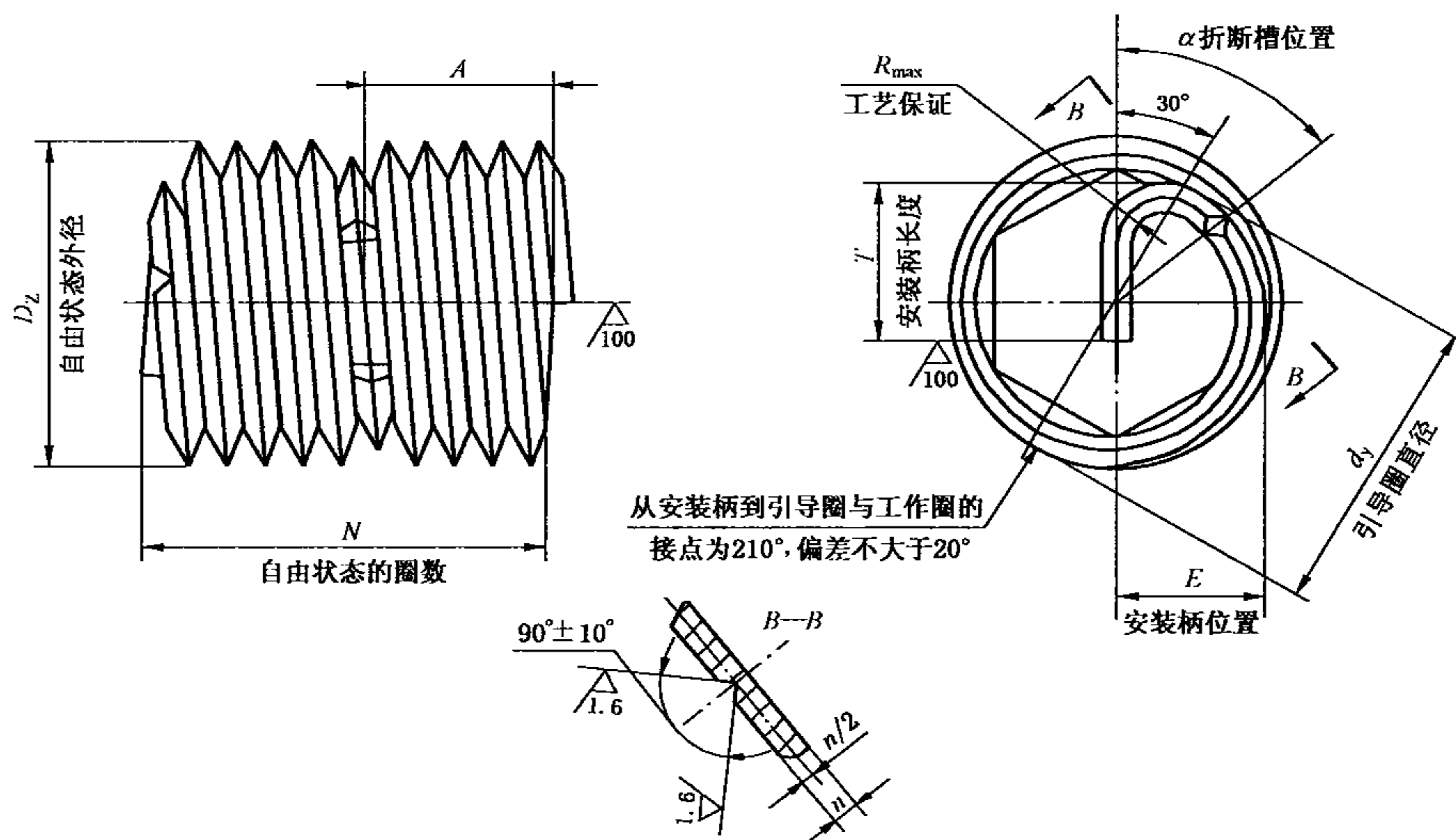
表2 尺寸(细牙螺纹)

单位为毫米

钢丝螺套规格	引导尺寸 d_y		自由状态外径 D_z		安装柄长度 T		折断槽位置 α		安装柄 转接圆弧 R_{\max}
	min.	max.	min.	max.	min.	max.	min.	max.	
M8×1	9.38	9.70	9.70	10.25	4.5	6.3	40°	80°	1.0
M10×1.25	11.57	11.87	11.87	12.65	5.7	7.8	40°	80°	1.2
M10×1	11.38	11.68	11.68	12.65	5.5	7.8	40°	80°	1.0
M12×1.5	14.02	14.40	14.40	15.00	6.8	9.4	30°	70°	1.6
M12×1.25	13.85	14.27	14.27	15.00	6.7	9.3	30°	70°	1.2
M12×1	13.78	14.18	14.18	15.00	6.5	9.3	30°	70°	1.2
M14×1.5	16.12	16.52	16.52	17.70	7.8	10.9	30°	70°	1.6
M14×1.25	16.05	16.45	16.45	17.70	7.7	10.8	30°	70°	1.2
M16×1.5	18.12	18.52	18.52	19.90	8.8	12.4	30°	70°	2.0
M18×2	20.67	21.07	21.07	22.00	10.1	14.0	30°	70°	3.0
M18×1.5	20.14	20.54	20.54	22.00	9.8	13.9	30°	60°	3.0
M20×2	22.67	23.12	23.12	24.20	11.1	15.5	30°	60°	3.0

表 2 (续)

单位为毫米

钢丝螺套规格	引导尺寸 d_y		自由状态外径 D_z		安装柄长度 T		折断槽位置 α		安装柄 转接圆弧 R_{\max}
	min.	max.	min.	max.	min.	max.	min.	max.	
M20×1.5	22.32	22.77	22.77	24.20	10.8	15.4	30°	60°	3.0
M22×2	24.67	25.27	25.27	26.80	12.1	17.0	30°	60°	3.0
M22×1.5	24.32	24.92	24.92	26.80	11.8	16.9	30°	60°	3.0
M24×2	26.67	27.27	27.27	29.10	13.1	18.5	30°	60°	3.0
M24×1.5	26.32	27.92	27.92	29.10	12.8	18.4	30°	60°	3.0
M27×2	29.67	30.27	30.27	32.40	14.6	20.8	30°	60°	3.0
M27×1.5	29.32	29.92	29.92	32.40	14.3	20.7	30°	60°	3.0
M30×2	32.67	33.27	33.27	35.81	16.1	23.0	30°	60°	3.0
M30×1.5	32.32	32.92	32.92	35.81	15.8	22.9	30°	60°	3.0
M33×2	35.67	36.27	36.27	39.01	17.6	25.3	30°	60°	3.0
M33×1.5	35.32	35.92	35.92	39.01	17.3	25.2	30°	60°	3.0
M36×3	39.75	40.45	40.45	42.67	19.6	27.8	30°	60°	3.0
M36×2	38.87	39.57	39.57	42.67	19.1	27.5	30°	60°	3.0
M39×3	42.75	43.45	43.45	45.75	21.1	30.1	30°	60°	3.0
M39×2	41.87	42.57	42.57	45.75	20.6	29.8	30°	60°	3.0

3.2 钢丝螺套安装柄位置尺寸 $E=d_y$ 实际/2。

3.3 钢丝螺套自由状态圈数和装配状态长度均应从与安装柄成 90°的位置起计算。

3.4 钢丝螺套的长度应按自由状态的整圈数选取(N , 见表 3 和表 4)。

3.5 钢丝螺套旋入内螺纹后的安装长度(L , 见表 3 和表 4)是通过两端头并垂直于轴线的两平面间距离。

3.6 以螺纹公称直径(d)的倍数表示的钢丝螺套公称长度与自由状态圈数和安装后长度的对照见附录 A。

3.7 根据用户要求,允许不制出折断槽。

表 3 自由状态圈数 N 和安装后长度 L (粗牙螺纹)

钢丝螺套 规格	自由状态圈数 $N \pm 1/4$ 圈																					
	4	5	6	7	8	9	10	11	12	13	14	15	16	17	18	19	20	21	22			
安装后长度 L (参考)/mm																						
M3	2.701	3.277	3.852	4.428	5.003	5.578	6.154	6.729	7.304	7.880	8.455	9.030	9.606	10.181	10.757	11.332	11.907	12.483	13.058			
M4	3.694	4.477	5.261	6.044	6.828	7.611	8.395	9.178	9.962	10.745	11.528	12.312	13.095	13.879	14.662	15.446	16.229	17.013	17.796			
M5	4.199	5.089	5.979	6.869	7.759	8.649	9.539	10.429	11.318	12.208	13.098	13.988	14.878	15.768	16.658	17.548	18.437	19.327	20.217			
M6	5.135	6.218	7.302	8.386	9.469	10.553	11.637	12.720	13.804	14.888	15.971	17.055	18.139	19.222	20.306	21.389	22.473	23.557	24.640			
M7	5.217	6.321	7.425	8.530	9.634	10.738	11.842	12.947	14.051	15.155	16.259	17.364	18.468	19.572	20.676	21.781	22.885	23.989	25.093			
M8	6.386	7.732	9.079	10.425	11.772	13.118	14.465	15.811	17.158	18.504	19.851	21.197	22.544	23.890	25.237	26.583	27.930	29.276	30.622			
M10	7.508	9.085	10.662	12.239	13.816	15.392	16.969	18.546	20.123	21.700	23.277	24.854	26.431	28.008	29.585	31.162	32.739	34.316	35.893			
M12	8.781	10.626	12.471	14.316	16.161	18.007	19.852	21.697	23.542	25.387	27.232	29.078	30.923	32.768	34.613	36.458	38.303	40.149	41.994			
M14	10.144	12.280	14.417	16.553	18.689	20.825	22.961	25.097	27.233	29.369	31.505	33.641	35.778	37.914	40.050	42.186	44.322	46.458	48.594			
M16	10.142	12.277	14.413	16.548	18.683	20.819	22.954	25.090	27.225	29.361	31.496	33.631	35.767	37.902	40.038	42.173	44.309	46.444	48.579			
M18	12.451	15.064	17.676	20.289	22.902	25.515	28.127	30.740	33.353	35.966	38.578	41.191	43.804	46.417	49.029	51.642	54.255	56.867	59.480			
M20	12.557	15.196	17.835	20.474	23.113	25.752	28.391	31.031	33.670	36.309	38.948	41.587	44.226	46.865	49.505	52.144	54.783	57.422	60.061			
M22	12.686	15.357	18.028	20.700	23.371	26.042	28.714	31.385	34.057	36.728	39.399	42.071	44.742	47.414	50.085	52.756	55.428	58.099	60.771			
M24	14.971	18.114	21.257	24.400	27.543	30.686	33.829	36.971	40.114	43.257	46.400	49.543	52.686	55.829	58.971	62.114	65.257	68.400	71.543			
M27	15.115	18.294	21.473	24.651	27.830	31.009	34.188	37.367	40.545	43.724	46.903	50.082	53.260	56.439	59.618	62.797	65.976	69.154	72.333			
M30	17.511	21.189	24.867	28.544	32.222	35.900	39.578	43.256	46.933	50.611	54.289	57.967	61.644	65.322	69.000	72.678	76.356	80.033	83.711			
M33	17.432	21.090	24.748	28.406	32.064	35.722	39.380	43.039	46.697	50.355	54.013	57.671	61.329	64.987	68.645	72.303	75.961	79.619	83.277			
M36	19.857	24.021	28.185	32.349	36.513	40.677	44.841	49.006	53.170	57.334	61.498	65.662	69.826	73.990	78.155	82.319	86.483	90.647	94.811			
M39	19.974	24.167	28.360	32.554	36.747	40.941	45.134	49.327	53.521	57.714	61.908	66.101	70.294	74.488	78.681	82.875	87.068	91.261	95.455			

表4 自由状态圈数 N 和安装后长度 L (细牙螺纹)

钢丝螺套规格	自由状态圈数 $N \pm 1/4$ 圈																					
	4	5	6	7	8	9	10	11	12	13	14	15	16	17	18	19	20	21	22			
	安装后长度 L (参考)/mm																					
M8×1	5.186	6.283	7.380	8.476	9.573	10.670	11.766	12.863	13.959	15.056	16.153	17.249	18.346	19.442	20.539	21.636	22.732	23.829	24.926			
M10×1.25	6.450	7.813	9.175	10.538	11.900	13.263	14.625	15.988	17.350	18.713	20.075	21.438	22.800	24.163	25.525	26.888	28.250	29.613	30.975			
M10×1	5.267	6.383	7.500	8.616	9.733	10.850	11.966	13.083	14.200	15.316	16.433	17.549	18.666	19.783	20.899	22.016	23.133	24.249	25.366			
M12×1.5	7.674	9.292	10.911	12.529	14.148	15.766	17.385	19.003	20.622	22.240	23.859	25.477	27.096	28.714	30.333	31.951	33.570	35.188	36.807			
M12×1.25	6.480	7.850	9.220	10.590	11.960	13.330	14.700	16.070	17.440	18.810	20.180	21.550	22.920	24.290	25.660	27.030	28.400	29.770	31.140			
M12×1	5.295	6.418	7.542	8.665	9.789	10.913	12.036	13.160	14.284	15.407	16.531	17.655	18.778	19.902	21.025	22.149	23.273	24.396	25.520			
M14×1.5	7.826	9.483	11.140	12.796	14.453	16.110	17.766	19.423	21.079	22.736	24.393	26.049	27.706	29.362	31.019	32.676	34.332	35.989	37.645			
M14×1.25	6.618	8.022	9.427	10.831	12.235	13.640	15.044	16.449	17.853	19.258	20.662	22.067	23.471	24.875	26.280	27.684	29.089	30.493	31.898			
M16×1.5	7.813	9.467	11.120	12.773	14.426	16.080	17.733	19.386	21.040	22.693	24.346	26.000	27.653	29.306	30.960	32.613	34.266	35.919	37.573			
M18×2	10.229	12.386	14.543	16.700	18.858	21.015	23.172	25.329	27.486	29.644	31.801	33.958	36.115	38.272	40.430	42.587	44.744	46.901	49.058			
M18×1.5	7.789	9.436	11.083	12.731	14.378	16.025	17.672	19.320	20.967	22.614	24.261	25.909	27.556	29.203	30.850	32.498	34.145	35.792	37.439			
M20×2	10.244	12.405	14.566	16.727	18.889	21.050	23.211	25.372	27.533	29.694	31.855	34.016	36.177	38.338	40.499	42.660	44.821	46.982	49.143			
M20×1.5	7.784	9.431	11.077	12.723	14.369	16.015	17.661	19.307	20.953	22.599	24.245	25.892	27.538	29.184	30.830	32.476	34.122	35.768	37.414			
M22×2	10.356	12.546	14.735	16.924	19.113	21.302	23.491	25.680	27.869	30.059	32.248	34.437	36.626	38.815	41.004	43.193	45.382	47.571	49.761			
M22×1.5	7.848	9.510	11.172	12.834	14.496	16.158	17.820	19.482	21.144	22.806	24.468	26.130	27.792	29.454	31.116	32.778	34.440	36.102	37.764			
M24×2	10.345	12.531	14.717	16.903	19.089	21.275	23.461	25.647	27.834	30.020	32.206	34.392	36.578	38.764	40.950	43.136	45.323	47.509	49.695			
M24×1.5	7.803	9.454	11.105	12.756	14.406	16.057	17.708	19.359	21.010	22.661	24.311	25.962	27.613	29.264	30.915	32.565	34.216	35.867	37.518			
M27×2	10.323	12.503	14.684	16.865	19.046	21.226	23.407	25.588	27.768	29.949	32.130	34.310	36.491	38.672	40.853	43.033	45.214	47.395	49.575			
M27×1.5	7.824	9.480	11.136	12.792	14.448	16.104	17.760	19.416	21.072	22.728	24.384	26.040	27.695	29.351	31.007	32.663	34.319	35.975	37.631			
M30×2	10.243	12.404	14.564	16.725	18.886	21.047	23.207	25.368	27.529	29.690	31.850	34.011	36.172	38.332	40.493	42.654	44.815	46.975	49.136			
M30×1.5	7.765	9.406	11.047	12.688	14.329	15.971	17.612	19.253	20.894	22.535	24.176	25.818	27.459	29.100	30.741	32.382	34.023	35.665	37.306			
M33×2	10.234	12.392	14.550	16.709	18.867	21.026	23.184	25.342	27.501	29.659	31.818	33.976	36.134	38.293	40.451	42.610	44.768	46.926	49.085			
M33×1.5	7.724	9.356	10.987	12.618	14.249	15.880	17.511	19.142	20.773	22.404	24.035	25.667	27.298	28.929	30.560	32.191	33.822	35.453	37.084			
M36×3	15.150	18.337	21.525	24.712	27.900	31.087	34.275	37.462	40.650	43.837	47.024	50.212	53.399	56.587	59.774	62.962	66.149	69.337	72.524			
M36×2	10.278	12.448	14.617	16.787	18.956	21.126	23.295	25.465	27.634	29.804	31.973	34.143	36.312	38.482	40.651	42.821	44.991	47.160	49.330			
M39×3	15.097	18.271	21.445	24.619	27.793	30.967	34.142	37.316	40.490	43.664	46.838	50.012	53.186	56.361	59.535	62.709	65.883	69.057	72.231			
M39×2	10.229	12.386	14.543	16.700	18.857	21.015	23.172	25.329	27.486	29.643	31.800	33.958	36.115	38.272	40.429	42.586	44.743	46.901	49.058			

4 锁紧圈

4.1 锁紧圈是由位于钢丝螺套中部的多边形组成,其两侧的非锁紧圈应不少于 2 圈,对于自由状态圈数大于 8 圈的钢丝螺套,应保持 A 段内的非锁紧圈的圈数为 $N_A = (N/3) \sim (N/3+1)$ 。

4.2 在保证锁紧力矩的条件下,锁紧圈的圈数、形状和尺寸由制造者确定。

5 技术条件

钢丝螺套的型面尺寸、技术要求、验收检查以及标志与包装按 GB/T 24425.6 的规定。

6 标记

6.1 标记方法

钢丝螺套标记的内容与顺序为:

类别 标准编号 钢丝螺套规格-自由状态圈数(无折断槽的钢丝螺套在自由状态圈数后加字母 W)

其他按 GB/T 1237 的规定。

6.2 标记示例

钢丝螺套规格为 M12、自由状态圈数为 10 圈的有折断槽的锁紧型钢丝螺套的标记:

钢丝螺套 GB/T 24425.3 M12-10

钢丝螺套规格为 M12×1.25、自由状态圈数为 12 圈的无折断槽的锁紧型钢丝螺套的标记:

钢丝螺套 GB/T 24425.3 M12×1.25-12W

附 录 A
(资料性附录)

钢丝螺套公称长度与自由状态圈数和安装后长度的对照

表 A.1 钢丝螺套公称长度与自由状态圈数和安装后长度的对照表(粗牙螺纹)

钢丝螺套规格	公称长度 ^a	自由状态圈数 N		安装后长度 L (参考)/mm	
		min.	max.	min.	max.
M3	$1d$	3.6	4.3	2.50	2.75
	$1.5d$	6.3	7.1	4.00	4.25
	$2d$	9.0	9.8	5.50	5.75
	$2.5d$	11.8	12.6	7.00	7.25
	$3d$	14.5	15.3	8.50	8.75
M4	$1d$	3.6	4.2	3.30	3.65
	$1.5d$	6.3	6.9	5.30	5.65
	$2d$	9.1	9.5	7.30	7.65
	$2.5d$	11.8	12.2	9.30	9.65
	$3d$	14.4	14.9	11.30	11.65
M5	$1d$	4.0	4.7	4.20	4.60
	$1.5d$	6.8	7.6	6.70	7.10
	$2d$	9.6	10.6	9.20	9.60
	$2.5d$	12.4	13.5	11.70	12.10
	$3d$	15.2	16.4	14.20	14.60
M6	$1d$	3.8	4.5	5.00	5.50
	$1.5d$	6.5	7.3	8.00	8.50
	$2d$	9.2	10.2	11.00	11.50
	$2.5d$	12.0	13.0	14.00	14.50
	$3d$	14.6	15.8	17.00	17.50
M7	$1d$	4.7	5.4	6.00	6.50
	$1.5d$	7.9	8.8	9.50	10.00
	$2d$	11.0	12.1	13.00	13.50
	$2.5d$	14.2	15.4	16.50	17.00
	$3d$	17.3	18.7	20.00	20.50
M8	$1d$	4.4	4.9	6.75	7.375
	$1.5d$	7.3	8.0	10.75	11.375
	$2d$	10.3	11.1	14.75	15.375
	$2.5d$	13.3	14.1	18.75	19.375
	$3d$	16.4	17.2	22.75	23.375

表 A.1 (续)

钢丝螺套规格	公称长度 ^a	自由状态圈数 N		安装后长度 L (参考)/mm	
		min.	max.	min.	max.
M10	$1d$	4.7	5.2	8.50	9.25
	$1.5d$	7.8	8.4	13.50	14.25
	$2d$	11.0	11.6	18.50	19.25
	$2.5d$	14.2	14.8	23.50	24.25
	$3d$	17.3	18.0	28.50	29.25
M12	$1d$	4.8	5.4	10.25	11.125
	$1.5d$	8.1	8.7	16.25	17.125
	$2d$	11.3	12.0	22.25	23.125
	$2.5d$	14.6	15.3	28.25	29.125
	$3d$	17.8	18.6	34.25	35.125
M14	$1d$	4.9	5.5	12.00	13.00
	$1.5d$	8.3	8.9	19.00	20.00
	$2d$	11.6	12.3	26.00	27.00
	$2.5d$	14.9	15.6	33.00	34.00
	$3d$	18.2	19.0	40.00	41.00
M16	$1d$	6.0	6.5	14.00	15.00
	$1.5d$	9.8	10.3	22.00	23.00
	$2d$	13.6	14.2	30.00	31.00
	$2.5d$	17.4	18.0	38.00	39.00
	$3d$	21.0	21.9	46.00	47.00
M18	$1d$	5.2	6.1	15.50	16.75
	$1.5d$	8.6	9.5	24.50	25.75
	$2d$	12.1	13.0	33.50	34.75
	$2.5d$	15.5	16.5	42.50	43.75
	$3d$	18.9	20.0	51.50	52.75
M20	$1d$	6.0	6.8	17.50	18.75
	$1.5d$	9.7	10.7	27.50	28.75
	$2d$	13.5	14.6	37.50	38.75
	$2.5d$	17.3	18.4	47.50	48.75
	$3d$	21.2	22.3	57.50	58.75
M22	$1d$	6.7	7.6	19.50	20.75
	$1.5d$	10.9	11.9	30.50	31.75
	$2d$	15.1	16.1	41.50	42.75
	$2.5d$	19.3	20.4	52.50	53.75
	$3d$	23.5	24.6	63.50	64.75

表 A.1 (续)

钢丝螺套规格	公称长度 ^a	自由状态圈数 N		安装后长度 L (参考)/mm	
		min.	max.	min.	max.
M24	$1d$	6.0	6.7	21.00	22.50
	$1.5d$	9.8	10.6	33.00	34.50
	$2d$	13.6	14.4	45.00	46.50
	$2.5d$	17.4	18.3	57.00	58.50
	$3d$	21.3	22.2	69.00	70.50
M27	$1d$	6.9	7.7	24.00	25.50
	$1.5d$	11.1	12.2	37.50	39.00
	$2d$	15.5	16.7	51.00	52.50
	$2.5d$	19.3	20.4	64.50	66.00
	$3d$	23.9	24.7	78.00	79.50
M30	$1d$	6.5	7.1	26.50	28.25
	$1.5d$	10.6	11.3	41.50	43.25
	$2d$	14.4	15.4	56.50	58.25
	$2.5d$	18.7	19.2	71.50	73.25
	$3d$	22.8	23.4	86.50	88.25
M33	$1d$	7.3	8.2	29.50	31.25
	$1.5d$	11.8	12.9	46.00	47.75
	$2d$	16.3	17.6	62.50	64.25
	$2.5d$	20.8	21.3	79.00	80.75
	$3d$	25.3	25.8	95.50	97.25
M36	$1d$	6.9	7.5	32.00	34.00
	$1.5d$	11.2	11.9	50.00	52.00
	$2d$	15.5	16.3	68.00	70.00
	$2.5d$	19.7	20.3	86.00	88.00
	$3d$	24.0	24.6	104.00	106.00
M39	$1d$	7.7	8.3	35.00	37.00
	$1.5d$	12.3	13.0	54.50	56.50
	$2d$	17.0	17.7	74.00	76.00
	$2.5d$	21.6	22.1	93.50	95.50
	$3d$	26.2	26.8	113.00	115.00

^a d 表示螺钉公称直径。

表 A.2 钢丝螺套公称长度与自由状态圈数和安装后长度的对照表(细牙螺纹)

钢丝螺套规格	公称长度 ^a	自由状态圈数 N		安装后长度 L (参考)/mm	
		min.	max.	min.	max.
M8×1	$1d$	5.7	6.4	7.00	7.50
	$1.5d$	9.3	10.2	11.00	11.50
	$2d$	12.9	14.0	15.00	15.50
	$2.5d$	16.5	17.7	19.00	19.50
	$3d$	20.1	21.5	23.00	23.50
M10×1.25	$1d$	5.7	6.4	8.75	9.375
	$1.5d$	9.3	10.2	13.75	14.375
	$2d$	12.9	14.0	18.75	19.375
	$2.5d$	16.6	17.8	23.75	24.375
	$3d$	20.2	21.6	28.75	29.375
M10×1	$1d$	7.6	7.8	9	9.5
	$1.5d$	12.1	12.3	14	14.5
	$2d$	16.3	16.8	19	19.5
	$2.5d$	20.7	21.3	24	24.5
	$3d$	25.3	25.8	29	29.5
M12×1.5	$1d$	6.2	6.7	10.5	11.25
	$1.5d$	9.8	10.2	16.5	17.25
	$2d$	13.5	14.0	22.5	23.25
	$2.5d$	15.7	16.2	28.5	29.25
	$3d$	20.7	21.1	34.5	35.25
M12×1.25	$1d$	7.1	7.9	10.75	11.375
	$1.5d$	11.5	12.5	16.75	17.375
	$2d$	15.8	17.0	22.50	23.375
	$2.5d$	20.2	21.6	28.75	29.375
	$3d$	24.5	26.1	34.75	35.375
M12×1	$1d$	9.3	9.7	11	11.5
	$1.5d$	14.5	14.9	17	17.5
	$2d$	19.5	19.9	23	23.5
	$2.5d$	25.1	25.6	29	29.5
	$3d$	30.5	30.9	35	35.5
M14×1.5	$1d$	6.9	7.7	12.50	13.25
	$1.5d$	11.1	12.1	19.50	20.25
	$2d$	15.4	16.5	26.50	27.25
	$2.5d$	19.6	20.9	33.50	34.25
	$3d$	23.8	25.3	40.50	41.25

表 A.2 (续)

钢丝螺套规格	公称长度 ^a	自由状态圈数 N		安装后长度 L (参考)/mm	
		min.	max.	min.	max.
M16×1.5	1 <i>d</i>	8.1	8.9	14.50	15.25
	1.5 <i>d</i>	13.0	14.0	22.50	23.25
	2 <i>d</i>	17.8	19.0	30.50	31.25
	2.5 <i>d</i>	22.6	24.1	38.50	39.25
	3 <i>d</i>	27.5	29.1	46.50	47.25
M18×2	1 <i>d</i>	7.1	7.5	16	17
	1.5 <i>d</i>	11.2	11.6	25	26
	2 <i>d</i>	15.1	15.5	34	35
	2.5 <i>d</i>	19.1	19.5	43	44
M18×1.5	1 <i>d</i>	9.4	10.2	16.50	17.25
	1.5 <i>d</i>	14.8	15.9	25.50	26.25
	2 <i>d</i>	20.3	21.6	34.50	35.25
	2.5 <i>d</i>	25.8	27.4	43.50	44.25
	3 <i>d</i>	31.2	33.1	52.50	53.25
M20×2	1 <i>d</i>	8	8.5	18	19
	1.5 <i>d</i>	12.5	13.0	28	29
	2 <i>d</i>	16.8	17.3	38	39
M20×1.5	1 <i>d</i>	10.6	11.4	18.50	19.25
	1.5 <i>d</i>	16.7	17.8	28.50	29.25
	2 <i>d</i>	22.7	24.1	38.50	39.25
	2.5 <i>d</i>	29.8	30.4	48.50	49.25
	3 <i>d</i>	34.9	36.7	58.50	59.25
M22×2	1 <i>d</i>	8.7	9.2	20	21
	1.5 <i>d</i>	13.6	14.1	31	32
	2 <i>d</i>	18.4	18.9	42	43
M22×1.5	1 <i>d</i>	11.8	12.7	20.50	21.25
	1.5 <i>d</i>	18.5	19.7	31.50	32.35
	2 <i>d</i>	25.2	26.6	42.50	43.25
	2.5 <i>d</i>	31.8	33.5	53.50	54.25
	3 <i>d</i>	38.5	40.5	64.50	65.25
	2.5 <i>d</i>	17.4	18.8	57.00	58.50
	3 <i>d</i>	21.3	22.2	69.00	70.50
M24×2	1 <i>d</i>	9.4	10.3	22.00	23.00
	1.5 <i>d</i>	14.8	16.0	34.00	35.00

表 A.2 (续)

钢丝螺套规格	公称长度 ^a	自由状态圈数 <i>N</i>		安装后长度 <i>L</i> (参考)/mm	
		min.	max.	min.	max.
M24×2	2 <i>d</i>	20.0	21.8	46.00	47.00
	2.5 <i>d</i>	25.8	27.5	58.00	59.00
	3 <i>d</i>	31.2	33.2	70.00	71.00
M24×1.5	1 <i>d</i>	12.9	13.4	22.5	23.25
	1.5 <i>d</i>	19.8	20.3	34.5	35.25
M27×2	1 <i>d</i>	10.7	11.2	25	26
	1.5 <i>d</i>	17.8	18.3	40.5	41.5
M27×1.5	1 <i>d</i>	14.7	15.2	25.5	26.25
	1.5 <i>d</i>	22.8	23.3	39	39.75
M30×2	1 <i>d</i>	12.3	12.8	28	29
	1.5 <i>d</i>	19.0	19.5	43	44
M30×1.5	1 <i>d</i>	16.5	17.0	28.5	29.25
	1.5 <i>d</i>	25.3	25.8	43.5	44.25
M33×2	1 <i>d</i>	13.7	14.2	31	32
	1.5 <i>d</i>	21.2	21.7	47.5	48.5
M33×1.5	1 <i>d</i>	18.5	19.0	31.5	32.25
	1.5 <i>d</i>	28.6	29.1	48	48.75
M36×3	1 <i>d</i>	9.9	10.4	33	34.5
	1.5 <i>d</i>	15.3	15.8	51	52.5
M36×2	1 <i>d</i>	14.1	14.6	34	35
	1.5 <i>d</i>	21.9	22.4	52	53
M39×3	1 <i>d</i>	10.8	11.3	36	37.5
	1.5 <i>d</i>	16.8	17.3	55.5	57
M39×2	1 <i>d</i>	16.3	16.8	37	38
	1.5 <i>d</i>	25	25.5	56.5	57.5

^a *d* 表示螺钉公称直径。



GB/T 24425.3-2009

版权专有 侵权必究

*

书号:155066·1-39818

定价: 18.00 元